

Index**1 Function Description**
.....**2 Technical Data**
.....**3 Indications**
.....

- 3.1 General Indications
- 3.2 Warning Signs / Indication Signs
- 3.3 Indications of Risks
- 3.4 Usage

4 Storage
.....**5 Mounting**
.....

- 5.1 Mounting of Coupling
- 5.2 Changes of Coupling
- 5.3 Mounting
- 5.4 Values of Misalignment

6 Use in Hazardous Locations
.....

- 6.1 Indications
- 6.2 Controlling Intervals
- 6.3 Wear Ratings
- 6.4 Identification
- 6.5 Initial Operation
- 6.6 Trouble in Service / Causes and Clearance
- 6.7 Declaration of Conformity



1 Function Description

The Softex® coupling is a torsionally flexible, puncture-proof threepart claw coupling. Due to the elastic gear ring it is in a position to damp impacts, torsional vibrations as well as noises. Furthermore the gear ring has a high resistance, elasticity as well as a good resistance to oils, fatty matters, a variety of solvents, ozone and influences of the weather. Due to this construction of the coupling (hub / elastic gear ring / hub) an angular resp. a radial misalignment of the shafts to be connected as well as thermal expansions will be compensated.

The utilization temperatures are between -50° and +120° C, depending on the type of gear ring. Short temperatures up to +150° C are admissible.

2 Technical Data

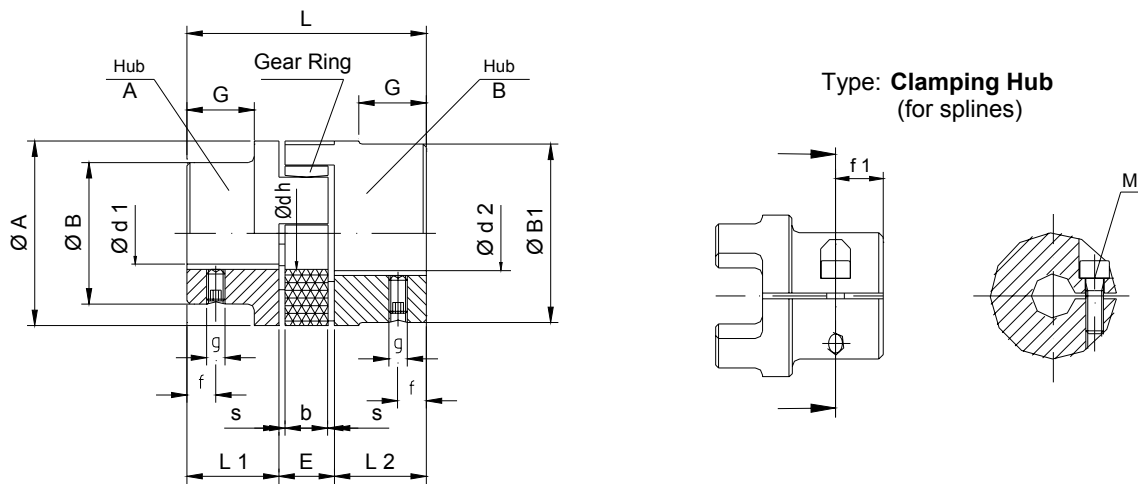

Materials: Cast Iron (GG) / Spheroidal Cast Iron (GGG) / Steel (St) / Stainless Steel (VA) / Sinter Steel (S)

Softex® Type	Hardnesses of Gear Ring				Bores				Dimensions (mm)													
	Nominal Torque (Nm)				Finish Bore d 1		Finish Bore d 2		A	B	B1	L	L1 + L2	E	s	b	G	dh	g	f	f1	M
	92 Sh A	95 Sh A	98 Sh A	64 Sh D	min	max	min	max														
14/ 16	7,5	-	12,5	-	-	-	4	16	30	-	-	35	11	13	1,5	10	-	10	M4	5	5	M3
19/24	10	-	17	-	-	-	6	24	40	-	-	66	25	16	2,0	12	-	18	M5	10	12	M6
24/30	35	-	60	75	-	-	8	32	55	-	-	78	30	18	2,0	14	-	27	M5	10	14	M8
28/38	95	-	160	200	-	-	10	38	65	-	-	90	35	20	2,5	15	-	30	M6	15	15	M8
38/45	190	-	325	405	14	38	40	45	80	66	78	114	45	24	3,0	18	37	38	M8	15	20	M10
42/55	265	-	450	560	16	42	45	55	95	75	93	126	50	26	3,0	20	40	46	M8	20	20	M10
48/60	310	-	525	655	19	48	50	60	105	85	103	140	56	28	3,5	21	45	51	M8	20	30	M10
55/70	375	-	625	825	22	55	60	70	120	98	118	160	65	30	4,0	22	52	60	M10	20	25	M12
65/75	625	900	-	1175	25	65	70	75	135	115	132	185	75	35	4,5	26	59	68	M10	20	30	M12
75/90	975	1500	-	2400	30	75	80	90	160	135	158	210	85	40	5,0	30	65	80	M10	25	30	M16
90/100	2400	3600	-	4500	-	-	45	100	200	-	170	245	100	45	5,5	34	81	100	M10	25	30	M20
100/110	3300	4950	-	-	-	-	45	110	225	-	180	270	110	50	6,0	38	89	113	M12	30	-	-
110/125	4000	6000	-	-	-	-	60	125	255	-	200	295	120	55	6,5	42	96	127	M16	35	-	-
125/145	5000	7500	-	-	-	-	60	145	290	-	230	340	140	60	7,0	46	112	147	M16	40	-	-

Flange Hub

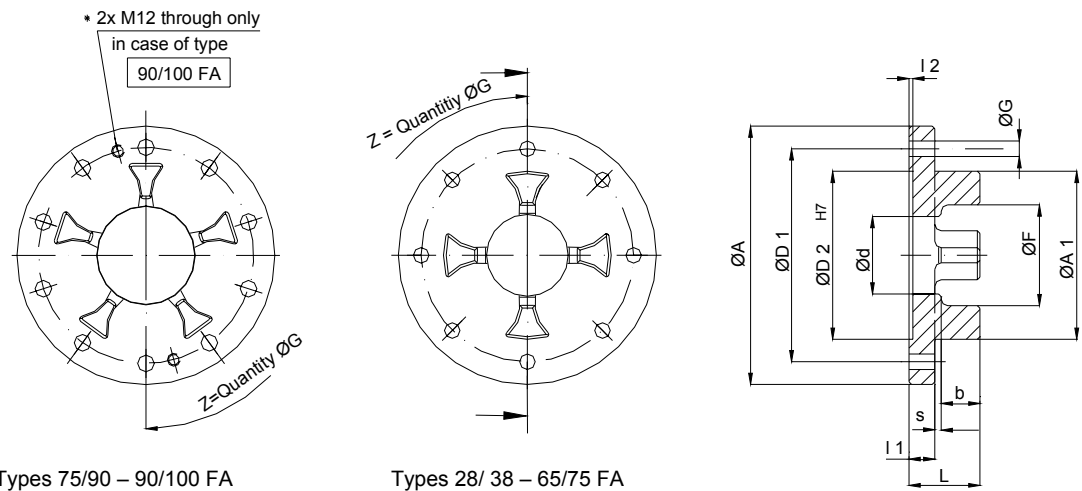

Types 75/90 – 90/100 FA

Types 28/ 38 – 65/75 FA

Type	Dimensions (mm)												
	A	A 1	L	l 1	s	b	F	l 2	D 1	D 2	d	G	Z
28 / 38 FA	100	65	27,5	10	2,5	15	39	1,5	80	65	30	7	6
38 / 45 FA	115	80	31	10	3	18	48	1,5	95	80	38	7	6
42 / 55 FA	140	95	35	12	3	20	57	2	115	95	46	9	6
48 / 60 FA	150	105	36,5	12	3,5	21	63	2	125	105	51	9	8
55 / 70 FA	175	120	42	16	4	22	74	2	145	120	60	11	8
65 / 75 FA	190	135	46,5	16	4,5	26	83	2	160	135	68	11	10
75 / 90 FA	215	160	54	19	5	30	98	2,5	185	160	80	14	10
90 / 100 FA	260	200	59,5	20	5,5	34	122	3	225	200	100	14	12

Starting torque for the fixing screws DIN 912 – 10.9

Thread	M6	M8	M10	M12
Torque (Nm)	14	35	69	120

3 Indications

3.1 General Indications

Before initial operation the installation instructions must be read carefully. Please pay attention to the security and warning indications.

The Softex® coupling is approved for application in hazardous locations. Please pay attention especially to the indications and prescriptions concerning security (Item 6).

This utilization and mounting description is part of the delivery extent and must be kept carefully.

3.2 Warning and Indication Signs

Passages with following signs must be paid attention to especially.

DANGER !	Danger of violation for persons
ATTENTION !	Engine trouble possible
INDICATION !	Important items
CAUTION !	Indications to protection in hazardous locations

3.3 Indications of Risks

Danger ! During mounting, service and maintenance you must ensure, that the complete system is protected from accidental activation, because there is a high danger of violation by rotating parts. Please imperatively pay attention to the following security indications:

- During all activities with and at the coupling please pay attention to the security prescriptions especially.
- Before starting the activities at the coupling the power unit must be switched off.
- The power unit must be protected from unintentional switching on by labels or removing of the protector.
- The unintentional touch of a running coupling must be prevented by appropriate safety devices.
- In case of operating couplings please pay attention to a sufficient safety clearance.

3.4 Usage

Following items must be paid attention to before mounting, operation or service:

- The operating and mounting instructions are to be read imperatively.
- Operations must only be made by an authorized specialist staff.

The coupling must only be applied in accordance to its corresponding technical data. Constructional changes of the coupling parts without any permission by the manufacturer are illegal and result in loss of warranty.

4 Storage

The coupling can be stored for approx. 6- 12 months at a dry place, due to the protection against corrosion, which must not be damaged.

The gear rings (Polyurethane) keep their qualities in case of a corresponding storage for approx. 5 years.

ATTENTION ! Please see to it, that there is no condensation in the storerooms. A relative humidity of less than 65% is favourable.

Furthermore please ensure, that there are no ozoning devices, such as illuminants or high voltage devices in the storerooms.

5 Mounting

5.1 Mounting of Coupling

Generally the coupling will be delivered in component parts. Before mounting the coupling must be checked in view of completeness.

Item.	Pcs.	Denomination
1	2	Hub
2	1	Gear Ring
3	2	Set Screw or Pan Head Screw

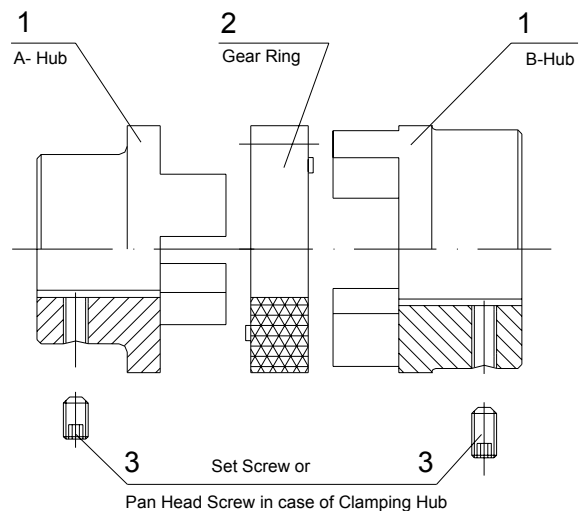

Detection Features of the Gear Rings (Item 2)

Shore Hardness (Shore)	Marking (Colour)
80 Sh A	blue
92 Sh A	white
95/98 Sh A	red
64 Sh D	green

5.2 Changes of Coupling

DANGER ! A change at the coupling parts is only permitted after having checked with the manufacturer.

For making the shaft bore by the user please pay attention to following items:

- The maximally admissible bore diameters $d1 + d2$ (see Technical Data) must not be exceeded. In case of disregard of these values, the coupling might break, and there is danger of life by flying fragments. This concerns all materials.
- The truth of running recommended by the manufacturer must be kept.
- For making the finish bore a careful alignment must be made.
- For the axial safety device please use a locking screw.
- Concerning a locking screw following starting torques must be kept (see table).

Starting Torques of the Locking Screws

Type	14	19	24	28	38	42	48	55	65	75	90	100	110	125
Thread	M4	M5	M5	M6	M8	M8	M8	M10	M10	M10	M10	M12	M16	M16
Torque (Nm)	1,5	2	2	4,8	10	10	10	17	17	17	17	40	80	80

Starting Torques of the Locking Screws for Clamping Hubs

Type	14	19	24	28	38	42	48	55	65	75	90
Thread	M3	M6	M8	M8	M10	M10	M10	M12	M12	M16	M20
Torque (Nm)	1,34	10,5	25	25	60	60	60	100	100	250	490

5.3 Mounting

INDICATION ! Before mounting, we recommend to check the bores, shaft, hub and adjusting spring regarding accuracy.

A warming of the hubs to approx. 80° C eases the bringing up to the shaft.

DANGER ! In order to avoid burnings by the touch of the heated hubs, please wear safety gloves.

CAUTION ! Please pay attention to danger of ignition in hazardous locations.

ATTENTION ! When mounting the coupling please ensure, that the dimension E (see Technical Data) must be absolutely kept, so that the gear ring will be axially movable during utilization. Disregard might lead to damages during operation.

- After mounting of the hubs to the shafts of the drive and load side the dimension "E" must be adjusted by relocation of the aggregates or the hubs on the shafts.
- Shafts with inserted adjusting spring and a smaller diameter than the inner diameter of the gear ring d_h are allowed to reach into the gear ring. The distance between the shafts must not be lower than 50% of the dimension "E"
- For saving the hubs by relocation please tighten the locking screw with a corresponding starting torque (Table 5.3)

5.4 Values of Misalignment

CAUTION ! During utilization in hazardous locations the ends of the shaft must be imperatively aligned, furthermore the operation life of the coupling can be increased by an exact alignment.
 Please keep the recommended values of misalignment (see table) without fail. When exceeding the values, the coupling will be damaged.
 For utilization in hazardous locations for the explosion groups IIC (Designation II 2G c IIC T4) the values must be reduced by 50%.

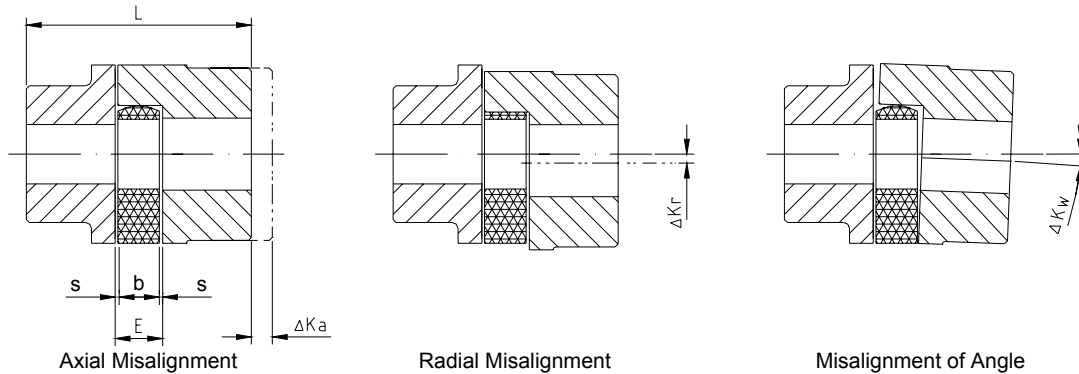

The values of the table are valid for an operating temperature $T = +30^\circ$

ATTENTION ! In case of an increase of the operating temperature the maximally permissible values of radial alignment and misalignment of angle must be multiplied by the temperature factor.

Softex® Type	Dimensions (mm)				Axial Misalignment ΔK_a (mm)	Radial Misalignment ΔK_r (mm)				Misalignment of Angle ΔK_w (°)			
	L	E	b	s		Speed 1/min				Speed 1/min			
						750	1000	1500	3000	750	1000	1500	3000
14/16	35	13	10	1,5	1,0	0,22	0,20	0,16	0,11	1,1	1,1	0,9	0,8
19/24	66	16	12	2,0	1,2	0,27	0,24	0,20	0,13	1,1	1,1	0,9	0,8
24/30	78	18	14	2,0	1,4	0,30	0,27	0,22	0,15	1,1	1,0	0,9	0,8
28/38	90	20	15	2,5	1,5	0,34	0,30	0,25	0,17	1,1	1,0	0,9	0,8
38/45	114	24	18	3,0	1,8	0,38	0,35	0,28	0,19	1,1	1,1	1,0	0,8
42/55	126	26	20	3,0	2,0	0,43	0,38	0,32	0,21	1,1	1,1	1,0	0,8
48/60	140	28	21	3,5	2,1	0,50	0,44	0,36	0,25	1,2	1,2	1,1	0,9
55/70	160	30	22	4,0	2,2	0,54	0,46	0,38	0,26	1,2	1,2	1,1	1,0
65/75	185	35	26	4,5	2,6	0,56	0,50	0,42	0,28	1,2	1,2	1,2	1,0
75/90	210	40	30	5,0	3,0	0,65	0,58	0,48	0,32	1,3	1,2	1,2	1,0
90/100	245	45	34	5,5	3,4	0,68	0,60	0,50	0,34	1,3	1,3	1,2	1,1
100/110	270	50	38	6,0	3,8	0,71	0,64	0,52	0,36	1,3	1,3	1,2	1,1
110/125	295	55	42	6,5	4,2	0,75	0,67	0,55	0,38	1,3	1,3	1,3	1,1
125/145	340	60	46	7,0	4,6	0,80	0,70	0,60	-	1,3	1,3	1,3	-

Temperature	-25 < +30°C	+40°C	+60°C	+80°C
Factor St	1,0	0,8	0,7	0,6

5.4 Values of Misalignment

The maximally admissible values of misalignment mentioned in the table must only be used proportionally in case of parallel radial alignment and alignment of angle.

Example 1:

$$\Delta K_R = 20\%$$

$$\Delta K_W = 80\%$$

Example 2:

$$\Delta K_R = 60\%$$

$$\Delta K_W = 40\%$$

$$\Delta K_{\text{totally}} = \Delta K_R + \Delta K_W \leq 100\%$$

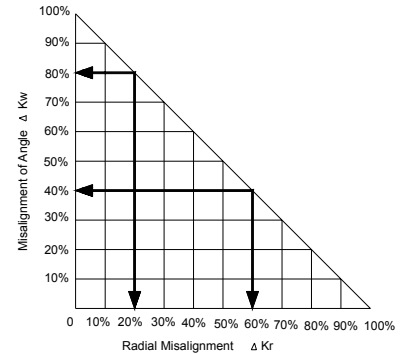

6 Use in Hazardous Locations

6.1 Indications

CAUTION ! Concerning the explosion groups IIB and IIC following materials are used by HBE:

Cast Iron	(GG25, GG20)	Stainless Steel (VA)
Spheroidal Cast Iron	(GGG40)	Sinter Steel (S)
Steel	(St)	

HBE does not use **Aluminium** for the couplings determined for hazardous locations.

6.2 Controlling Intervals

Explosion Group	Controlling Intervals
II 2G c IIB T4 X II 2D c T 110°C X I M2 c X	<p>After an operating time of 3.000 h, 6 months after initial operation of the coupling at latest, the elastic gear ring must be put to test (visual check, torsion test).</p> <p>In case of an unessential or no wear of the gear ring during first check the check cycles can be fixed to an operating time of 6 000 h or 18 months at the same operating conditions.</p> <p>In case of an increased wear at first check we recommend to proceed as follows:</p> <ul style="list-style-type: none"> • Exchange of the gear ring • Determination of cause • Accomodation of the check cycles to the operating conditions
II 2G c IIC T4 X	<p>After an operating time of 2.000 h, 3 months after initial operation of the coupling at latest, the elastic gear ring must be put to test (visual check, torsion test).</p> <p>In case of an unessential or no wear of the gear ring during first check the cycles can be fixed to an operating time of 4.000 h or 12 months at the same operating conditions.</p> <p>In case of an increased wear at first check we recommend to proceed as follows:</p> <ul style="list-style-type: none"> • Exchange of the gear ring • Determination of cause • Accomodation of the check cycles to the operating conditions

6.3 Wear Ratings

The check of the wearability is made by guide between tooth flank and claw of coupling.

In case of a backlash > X mm the gear ring must be exchanged.

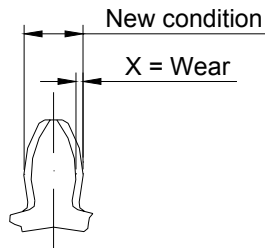

Softex® Type	Wearability X max. (mm)
14/ 16	2
19/24	3
24/30	3
28/38	3
38/45	3
42/55	4
48/60	4
55/70	5
65/75	5
75/90	6
90/100	8
100/110	9
110/125	9
125/145	10

6.4 Identification

Couplings for use in hazardous locations must be marked for the respectively allowable applicational conditions.

Identification mark : **II 2G c IIB T4 X** **II 2G c IIC T4 X**

II 2D c T 110°C X **I M2 c X**

The explosion groups **IIB** and **IIA** as well as the temperature ranges T3 – T1 are contained in the identification mark **II 2G c IIC T4 X**.

6.5 Initial Operation

Before initial operation of the coupling following checks and possible corrections must be made:

- Check of alignment
- Check of misalignment
- Check of spacing E
- Check of the draft of the set screws in the hubs
- Check of the draft of the fixing screws concerning flange hubs

CAUTION ! In hazardous locations the set screws for the fixing of the hubs and the fixing screws of the flange hubs must be covered against self release, e. g. sticking by Loctite 270.

Finally the user has to fit a complete protection consisting of a fix cover.
The cover must protect the coupling especially from falling objects. The covers can be provided with regular openings. Following dimensions must not be exceeded.

	Round Openings Ø (mm)	Rectangular Openings Side Length (mm)
Top of Cover	4	4
Side of Cover	8	8

The distance of the cover to rotating parts must be 5 mm at least.

The cover must be electrically conductive and be included in the potential compensation.

The cover is only allowed to be taken off during stand still.

Aluminium bell-housing (also with damping flange) are tolerated for pod, in case the share of magnesium is less than 7,5%..

CAUTION ! When mounting the coupling to machines of category 2D please ensure, that there is no dust between cover and coupling. The couplings must not run in dust particles. When using the coupling in machines of group I, category M2 the cover must not consist of light metal (higher mechanical load).

During operation of the coupling please pay attention to:

- Changed operation noises
- Occurring vibrations

ATTENTION ! In case of changes or irregularities during the operation of the coupling, the power unit must be switched off immediately. The cause of the disturbance must be found out by the check list "Trouble in service" and be removed, if possible.

6.6 Trouble in Service / Causes and Clearance

A disturbance by break of the fixing screws of the flange couplings must be excluded under observance of the criterions of selection.

Disturbances	Causes	Indications of Risks for Hazardous Locations	Clearance
Changes of operation noises Vibrations	Fault of alignment	High temperatures at the surface lead to danger of ignition	<ul style="list-style-type: none"> • Stop the unit • Check and remove changes in construction • Check the drive unit regarding damages • Check and correct, if necessary, alignment and dimension E of the coupling • Check the wear of the gear ring and exchange, if necessary
	Loose screws for axial locking of hub	Danger of ignition by hot surface and sparking	<ul style="list-style-type: none"> • Stop the unit • Check and correct alignment and dimension E of the coupling • Check the wear of the gear ring and exchange, if necessary • Retighten the fixing screws by the starting torque and protect it from self-release by Loctite
Disturbances	Causes	Indications of Risks for Hazardous Locations	Clearance

Changes of operation noises Vibrations	Short-term torque transfer by metal contact	Danger of ignition by sparking	<ul style="list-style-type: none"> • Stop the unit • Dismount the coupling • Remove the gear ring • Check the parts of the coupling and exchange damaged parts • Renew the gear ring • Check and, if necessary, correct the alignment • Tighten the fixing screws by the starting torque and protect it from self-release by Loctite
Break of claw	Operating error Deadlock and break by power conc. the claws Overcharge	Danger of ignition by sparking due to metal contact	<ul style="list-style-type: none"> • Stop the unit • Dismount the coupling • Check the shafts and adjusting springs reg. damages • Check the drive unit regarding damages • Mount the complete coupling • Check the alignment • Tighten the fixing screws by the starting torque and protect it from self-release by Loctite
	The parameters for the determination of the coupling do not correspond to the actual operation conditions. Dimensions of coupling too small.		<ul style="list-style-type: none"> • Stop the unit • Dismount the coupling • Check the shafts and adjusting springs reg. damages • Check the operating parameter and choose a harder gear ring resp. bigger coupling • Check the mounting space when deciding for a bigger coupling • Mount the complete coupling • Check and correct, if necessary, alignment and dimension E of the coupling • Tighten the fixing screws by the starting torque and protect it from self-release by Loctite
Increased wear of gear ring Claws smash during torque transfer			
Early wear of gear ring	Error of alignment Dimension E was not kept	Danger of ignition by high temperatures at the gear ring	<ul style="list-style-type: none"> • Stop the unit • Check the mounting and remove errors of alignment • Check the parts of the coupling and exchange damaged parts • Exchange the gear ring • Check and correct, if necessary, alignment and dimension E of the coupling • Tighten the fixing screws by the starting torque and protect it from self-release by Loctite
Disturbances	Causes	Indications of Risks for Hazardous Locations	Clearance

Early wear of gear ring	Torsional vibrations destroy the charged teeth inside	Danger of ignition by sparking during metal contact of the claws	<ul style="list-style-type: none"> • Stop the unit • Check the parts of the coupling and exchange damaged parts • Find out and remove cause of vibration • Exchange the gear ring (eventually choose smaller or higher shore hardness, please pay attention to the size of the coupling) • Check and correct, if necessary, alignment and dimension E of the coupling • Tighten the fixing screws by the starting torque and protect it from self-release by Loctite
	Inadmissibly high temperatures by warming of contact	Danger of ignition by sparking during metal contact of the claws	<ul style="list-style-type: none"> • Stop the unit • Check the parts of the coupling and exchange damaged parts • Find out and remove the source of heat • Exchange the gear ring • Check and correct, if necessary, alignment and dimension E of the coupling • Tighten the fixing screws by the starting torque and protect it from self-release by Loctite
	Aggressive conditions of environment (steams, chemicals, etc.) and / or liquids (biol. oils)		<ul style="list-style-type: none"> • Stop the unit • Check the parts of the coupling and exchange damaged parts • Check and correct the conditions of environment • Check the operating medium and change, if possible • Exchange the gear ring • Check and correct, if necessary, alignment and dimension E of the coupling • Tighten the fixing screws by the starting torque and protect it from self-release by Loctite

6.7 Declaration of Conformity

Declaration of Conformity

According to the EG rules 94/9/EG dated 23rd March, 1994 and the legal requirements

the manufacturer

**HBE GmbH
Hönnestr. 47
D-58809 Neuenrade**

hereby declares that the following products described in the operation and mounting instructions

Softex® - Elastic Couplings

are non-electric devices acc. to the EG rules 94/9/EG and meet the security and healthy prescriptions for the conception and the construction of the device concerning the intended use in hazardous locations as stated in subjoinder II of the guide. A conformity to the norms EN 1127-1:1997, EN 1127-2:2002, EN 13463-1:2001 and EN 13463-5:2003 is given.

Following test certificate of type is existing for the **Softex® Elastic Couplings**:

IBExU04ATEXB027 X

Acc. to RL 94/9/EG the technical documentation is deposited at the following place:

**IBExU
Institut für Sicherheitstechnik GmbH
Fuchsmühlenweg 7
D-09599 Freiberg**

Neuenrade, 20.06.05
Date

i.V. _____
Detlef Lengelsen
Product Manager

i.V. _____
Peter Bajorat
QS-Manager