

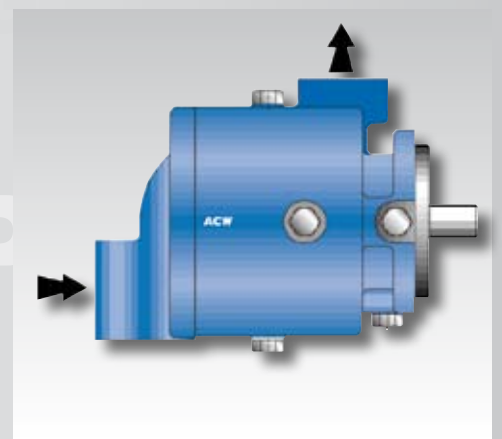

C-RANGE
C-RANGE METERING
C-RANGE METERING
METERING PUMPS
METERING P
METERING

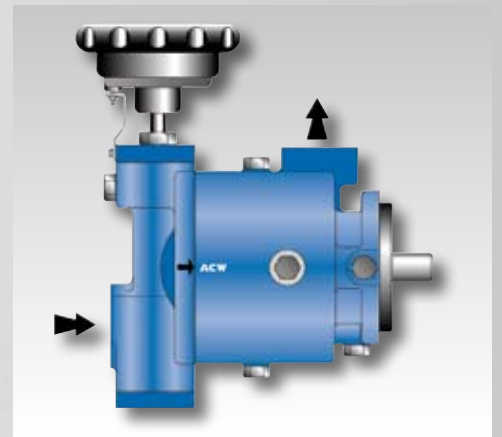

C-RANGE METERING PUMPS

TECHNICAL DATA

See Note	Pump Range	C- Range				
	Model	C01	C04	C07	C20	C38
	Geometric displacement (cc/rev)	2	6	11.5	33	62
1	Maximum speed rev/min	1800	1800	1800	1800	1800
2	Minimum speed rev/min	200	200	200	200	200
3	Max outlet pressure TDI (bar)	210	210	210	210	210
	Max outlet pressure MDI, polyol (bar)	250	250	250	250	250
4	Min outlet pressure (bar) above inlet	2	2	2	2	2
5	Max inlet pressure (bar)	20	20	20	20	20
	Min inlet pressure (bar)	See Graph 2				
	Max viscosity	2000 cSt for, higher viscosities consult ROTARY POWER				
	Min viscosity	1cSt				
6	Recommended fluid cleanliness	ISO/DIS 4406 Polyol ISO code 18/13 Isocyanate code 16/11				
	Max temperature	80 °C				
	Optimum temperature	10 to 50 °C				
	Approximate weight (kg)	16	18	20	30	40

NOTES FOR TECHNICAL DATA TABLE

- Maximum allowable speed reduces for high viscosity fluids. Refer to Graph 1.
- Minimum speed is determined by flow stability.
- Pressures shown are for fluids complying with cleanliness codes stated in this table.
- Outlet pressure must never fall below inlet pressure this includes during stationary and start up conditions.
- Inlet pressure should be kept to the minimum value possible, based on the characteristics of the fluid and other factors – see application section.
- These recommendations for fluid cleanliness are made, based on the minimum conditions for optimum life. Like any mechanical component, normal wear will be accelerated either, by poor filtration and contaminated fluid or, by the use of abrasive substances such as “carbon black”.

Guide to pump selection

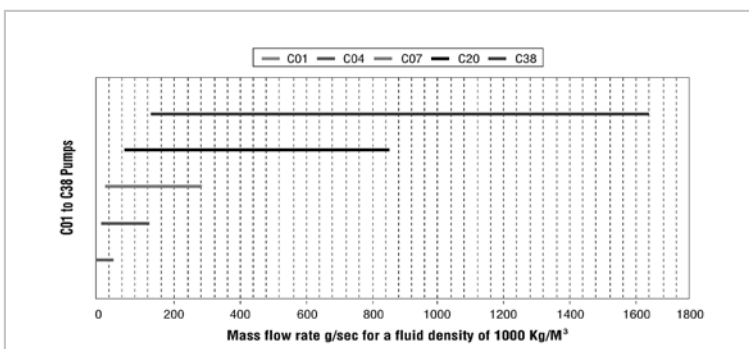

Graph 1

Maximum pump speed (RPM) for fluid viscosity

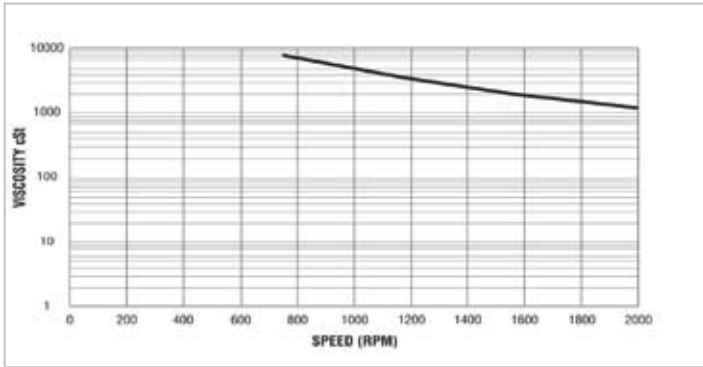

Graph 2

C pump minimum boost requirement (1500 rpm) and minimum discharge pressure



PUMP APPLICATION

OPERATING PRESSURES – GENERAL

The pump design features hydrostatic bearing faces for optimum efficiency and long life. The hydrostatic balance required for these bearings means that inlet pressure must never exceed outlet pressure, even when the pump is not rotating. This is normally simple to achieve on tank pressured systems. For systems using boost pump this may be possible by using a relief valve or by placing a check valve in parallel with the pump. This is to allow a possible flow from inlet to outlet so that pressures can be balanced from inlet to outlet during start up of the pump (this valve should close as soon as outlet pressure exceeds inlet pressure).

WARNING

Outlet pressure from the pump must always exceed inlet pressure to the pump. Failure to comply with this instruction may lead to damage or complete failure of the pump.

IMPORTANT INFORMATION – PLEASE READ CAREFULLY

OUTLET PRESSURE

If the fluid contains certain fillers, blowing agents or the other additives, maximum outlet pressure may have to be limited in order to achieve reliable running and reasonable life. For applications on fluids, which include the above, or other additives please consult ROTARY POWER for further advice.

Maximum pump outlet pressures should not exceed the following in any circumstances

TDI fluid	210 bar
MDI, Polyol fluid	250 bar

Minimum outlet pressure 2 bar or a value equal to or higher than inlet pressure, whichever is greater.

INLET PRESSURE

To achieve the correct inlet pressure conditions, the following must be considered at the inlet port of the pump.

1. Inlet pressure must not exceed outlet pressure.
2. Inlet pressure must be high enough to keep the fluid stable in all conditions, consistent with the fluid manufacturers recommendations.
3. Inlet pressure must be high enough with more viscous fluids, to eliminate cavitation within the pump.
4. Shaft seal life is dependant upon the case pressure (also pump speed and fluid cleanliness). The lower the inlet pressure, the longer the seal life. Therefore the correct procedure for specifying the required pressure at the inlet port of the pump is:
 - A. Check requirements for the specified fluid with the fluid supplier / manufacturer.
 - B. Check with the chart 1 for the minimum inlet pressure at the inlet port for the specified fluid viscosity.

SHAFT SEAL

Shaft seal life is dependant upon many factors, some examples are :

1. Shaft speed
2. Fluid lubricity
3. Fluid pressure
4. Fluid contaminant level
5. Nature and size of fillers used.



ORDERING CODE

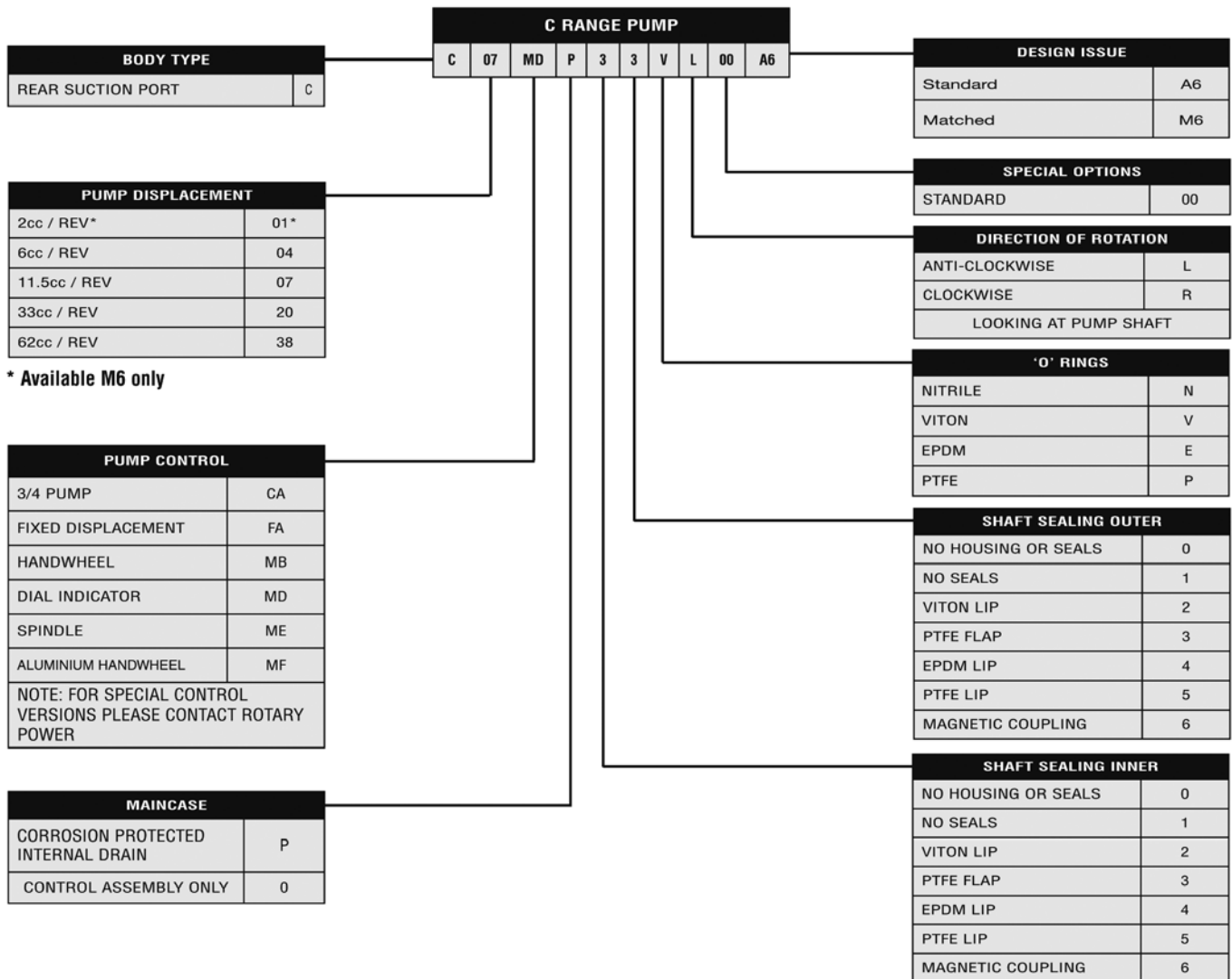

*Larger capacity pumps up to 125 cm³ / Rev are available from ROTARY POWER.
Details may be found in the A range Axial Piston Pump and Motor catalogue.

ROTARY POWER
Vertriebsgesellschaft mbH

Nordstraße 78
52078 Aachen-Brand
Germany



Phone +49 (0) 241 / 9 55 19-0
Fax +49 (0) 241 / 9 55 19-19

info@rotarypower.de
www.rotarypower.de